

smar
FIRST IN FIELDBUS

IF302

OPERATION & MAINTENANCE
INSTRUCTIONS MANUAL

TRIPLE CHANNEL CURRENT TO FIELDBUS CONVERTER

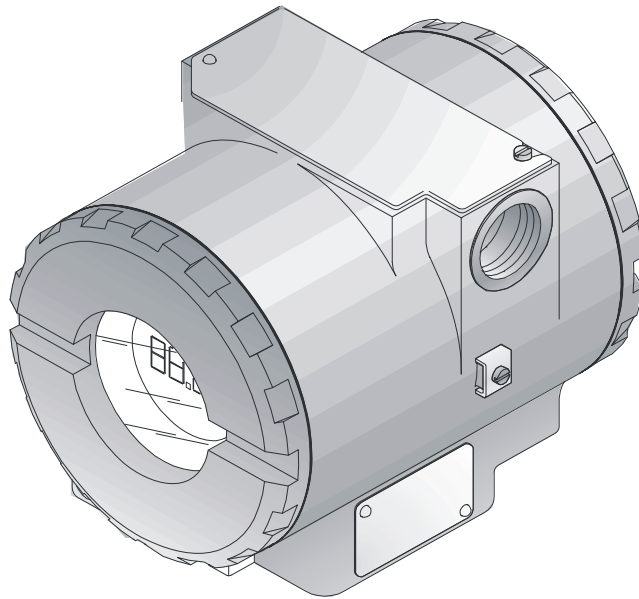

MAY / 11
IF302
VERSION 3



smar
www.smar.com

Specifications and information are subject to change without notice.
Up-to-date address information is available on our website.

web: www.smar.com/contactus.asp

INTRODUCTION

The **IF302** is a converter mainly intended to interface analog transmitters to a Fieldbus network. The **IF302** receives up to three current signal typically 4-20 mA or 0-20 mA, and makes them available to Fieldbus system. The digital technology used in the **IF302** enables an easy interface between the field and the control room and it has several interesting features that reduce considerably the installation, operation and maintenance costs.

The **IF302** is part of SMAR's complete 302 line of Fieldbus devices.

Fieldbus, is not only a replacement for 4-20 mA or intelligent/smart transmitter protocols, it contains much more. Fieldbus is a complete system enabling distribution of the control function on equipment in the field.

Some of the advantages of bi-directional digital communications are known from existing smart transmitter protocols: Higher accuracy, multi-variable access, remote configuration and diagnostics, and multi-dropping of several devices on a single pair of wires.

Those protocols were not intended to transfer control data, but maintenance information. Therefore they were slow and not efficient enough to be used as control network.

The main requirements for Fieldbus were to overcome these problems. Closed loop control with performance like a 4-20 mA system requires higher speed. Since higher speed means higher power consumption, this clashes with the need for intrinsic safety. Therefore a moderately high communication speed was selected, and the system was designed to have a minimum of communication overhead. Using scheduling, the system controls variable sampling, algorithm execution and communication to optimize the usage of the network, not losing time. Thus, high closed loop performance is achieved.

Using Fieldbus technology, with its capability to interconnect several devices, very large control schemes can be constructed. In order to be user friendly the function block concept was introduced (users of SMAR CD600 should be familiar with this, since it was implemented several years ago). The user may now easily build complex control strategies. Another advantage is added flexibility; the control strategy may be edited without having to rewire or change any hardware.

The **IF302**, like the rest of the 302 family, has several Function Blocks built in, like PID controller, Input Selector, Arithmetic, Signal Characterizer and Flow Totalization. These useful blocks eliminate the need for separate devices and reduce communication and therefore decreasing dead-time and making the control tighter, not to mention the reduction in cost. Other function blocks are also available, allowing flexibility in control strategy implementation.

The need for implementation of Fieldbus in small as well as large systems was considered when developing the entire 302 line of Fieldbus devices. They have the common features of being able to act as a master on the network and be configured locally using a magnetic tool, eliminating the need for a configurator or console in many basic applications.

Get the best result of the **IF302** by carefully reading these instructions.

This product is protected by US patent number **5,706,007**.



WARNING

This Manual is compatible with version 3.XX, where 3 denote software version and XX software release. The indication 3.XX means that this manual is compatible with any release of software version 3.

Waiver of responsibility

The contents of this manual abides by the hardware and software used on the current equipment version. Eventually there may occur divergencies between this manual and the equipment. The information from this document are periodically reviewed and the necessary or identified corrections will be included in the following editions. Suggestions for their improvement are welcome.

Warning

For more objectivity and clarity, this manual does not contain all the detailed information on the product and, in addition, it does not cover every possible mounting, operation or maintenance cases.

Before installing and utilizing the equipment, check if the model of the acquired equipment complies with the technical requirements for the application. This checking is the user's responsibility.

If the user needs more information, or on the event of specific problems not specified or treated in this manual, the information should be sought from Smar. Furthermore, the user recognizes that the contents of this manual by no means modify past or present agreements, confirmation or judicial relationship, in whole or in part.

All of Smar's obligation result from the purchasing agreement signed between the parties, which includes the complete and sole valid warranty term. Contractual clauses related to the warranty are not limited nor extended by virtue of the technical information contained in this manual.

Only qualified personnel are allowed to participate in the activities of mounting, electrical connection, startup and maintenance of the equipment. Qualified personnel are understood to be the persons familiar with the mounting, electrical connection, startup and operation of the equipment or other similar apparatus that are technically fit for their work. Smar provides specific training to instruct and qualify such professionals. However, each country must comply with the local safety procedures, legal provisions and regulations for the mounting and operation of electrical installations, as well as with the laws and regulations on classified areas, such as intrinsic safety, explosion proof, increased safety and instrumented safety systems, among others.

The user is responsible for the incorrect or inadequate handling of equipments run with pneumatic or hydraulic pressure or, still, subject to corrosive, aggressive or combustible products, since their utilization may cause severe bodily harm and/or material damages.

The field equipment referred to in this manual, when acquired for classified or hazardous areas, has its certification void when having its parts replaced or interchanged without functional and approval tests by Smar or any of Smar authorized dealers, which are the competent companies for certifying that the equipment in its entirety meets the applicable standards and regulations. The same is true when converting the equipment of a communication protocol to another. In this case, it is necessary sending the equipment to Smar or any of its authorized dealer. Moreover, the certificates are different and the user is responsible for their correct use.

Always respect the instructions provided in the Manual. Smar is not responsible for any losses and/or damages resulting from the inadequate use of its equipments. It is the user's responsibility to know and apply the safety practices in his country.

TABLE OF CONTENTS

SECTION 1 - INSTALLATION	1.1
GENERAL	1.1
MOUNTING.....	1.1
ELECTRIC WIRING	1.1
TOPOLOGY AND NETWORK CONFIGURATION	1.3
INPUT WIRING	1.4
SECTION 2 - OPERATION	2.1
FUNCTIONAL DESCRIPTION – ELECTRONICS.....	2.1
SECTION 3 - CONFIGURATION	3.1
TRANSDUCER BLOCK	3.1
HOW TO CONFIGURE A TRANSDUCER BLOCK.....	3.1
TERMINAL NUMBER.....	3.1
PRIMARY VALUE STATUS	3.2
CURRENT TRIM	3.2
VIA LOCAL ADJUSTMENT.....	3.5
DISPLAY TRANSDUCER BLOCK	3.5
DEFINITION OF PARAMETERS AND VALUES	3.6
PROGRAMMING USING LOCAL ADJUSTMENT	3.9
J1 JUMPER CONNECTIONS	3.10
W1 JUMPER CONNECTIONS.....	3.10
SECTION 4 - MAINTENANCE	4.1
GENERAL	4.1
TROUBLESHOOTING	4.1
DISASSEMBLY PROCEDURE	4.2
REASSEMBLE PROCEDURE	4.2
BOARDS INTERCHANGEABILITY	4.2
EXPLODED VIEW.....	4.3
ACCESSORIES	4.3
SPARE PARTS LIST.....	4.4
SECTION 5 - TECHNICAL CHARACTERISTICS	5.1
FUNCTIONAL SPECIFICATIONS.....	5.1
PERFORMANCE SPECIFICATIONS.....	5.1
PHYSICAL SPECIFICATIONS.....	5.2
ORDERING CODE.....	5.2
RETURNING MATERIALS.....	5.2
APPENDIX A – SRF – SERVICE REQUEST FORM	A.1
APPENDIX B - SMAR WARRANTY CERTIFICATE	B.1

Installation Flowchart

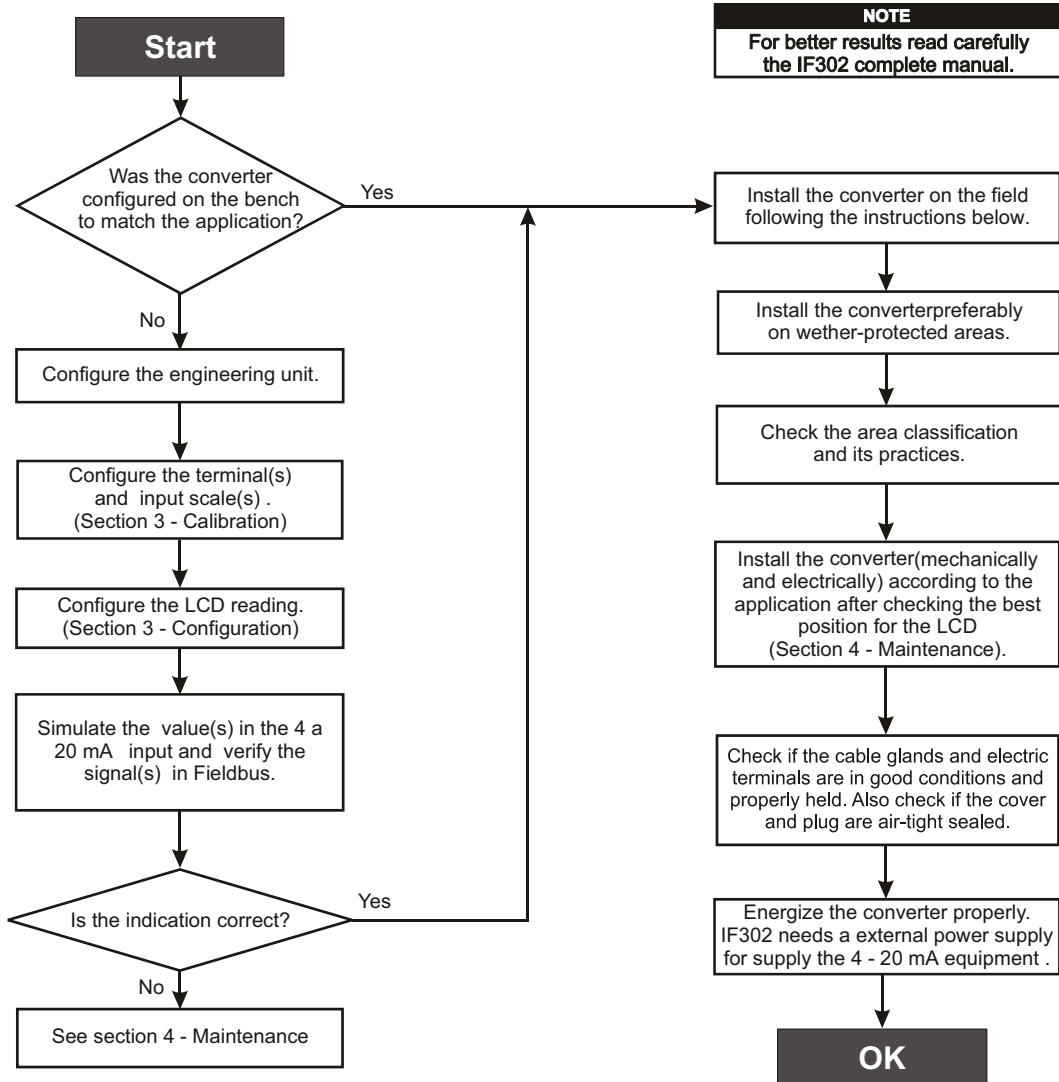

Section 1

INSTALLATION

General

The overall accuracy of measurement and control depends on several variables. Although the converter has an outstanding performance, proper installation is essential, in order to maximize its performance.

Among all factors, which may affect converter accuracy, environmental conditions are the most difficult to control. There are, however, ways of reducing the effects of temperature, humidity and vibration.

Locating the converter in areas protected from extreme environmental changes can improve the converter performance.

In warm environments, the converter should be installed to avoid as much as possible, direct exposure to the sun. Installation close to lines and vessels subjected to high temperatures should also be avoided.

Use of sunshades or heat shields to protect the converter from external heat sources should be considered, if necessary.

Humidity is fatal to electronic circuits. In areas subjected to high relative humidity, the O-rings for the electronics cover must be correctly placed. Removal of the electronics cover in the field should be reduced to the minimum necessary, since each time it is removed the circuits are exposed to the humidity. The electronic circuit is protected by a humidity proof coating, but frequent exposures to humidity may affect the protection provided. It is also important to keep the covers tightened in place. Every time they are removed, the threads are exposed to corrosion, since painting cannot protect these parts. Code-approved sealing methods on conduit entering the converter should be employed.

Mounting

Using the bracket, the mounting may be done in several positions, as shown on Figure 1.3 - Dimensional Drawing and Mounting Positions.

For better visibility, the digital indicator may be rotated in steps of 90° (See Section 4 - Maintenance Procedures).

Electric Wiring

Access the wiring block by removing the Electrical Connection Cover. This cover can be locked closed by the cover locking screw (See Figure 1.1 - Cover Locking). To release the cover, rotate the locking screw clockwise.

Cable access to wiring connections is obtained by one of the two conduit outlets. Conduit threads should be sealed by means of code-approved sealing methods. The unused outlet connection should be plugged accordingly.

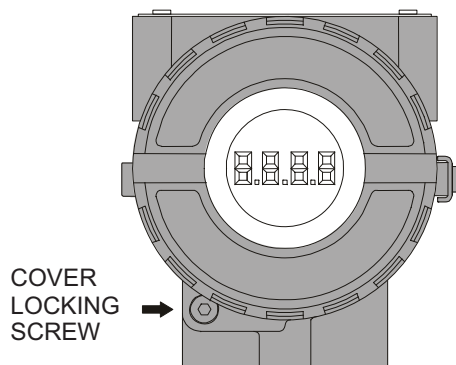

Figure 1.1 - Cover Locking

For convenience there are three ground terminals: one inside the cover and two externals, located close to the conduit entries.

The wiring block has screws, on which fork or ring type terminals can be fastened, see Figure 1.2 - Terminal Block.

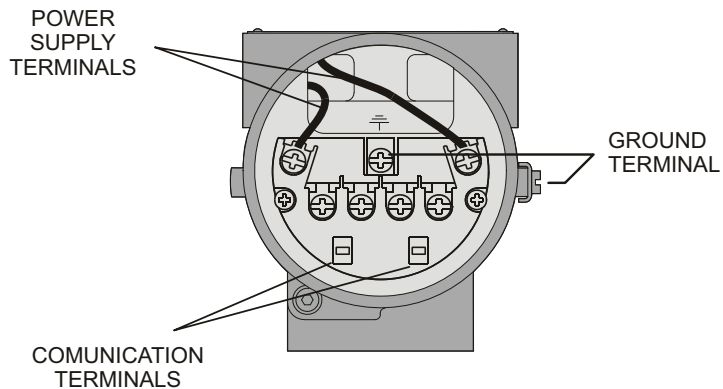

Figure 1.2 - Terminal Block

The IF302 uses the 31.25 kbit/s voltage mode option for the physical signaling. All other devices on the same bus must use the same signaling. 12 to 16 devices can be connected in parallel along the same pair of wires.

Various types of Fieldbus devices may be connected on the same bus.

The IF302 is powered via the bus. The limit for such devices is 16 for one bus (one segment) for non-intrinsically safe requirement.

In hazardous area, the number of devices may be limited by intrinsically safe restrictions.

The IF302 is protected against reverse polarity, and can withstand ± 35 VDC without damage.



NOTE

Please refer to the General Installation, Operation and Maintenance Manual for more details.

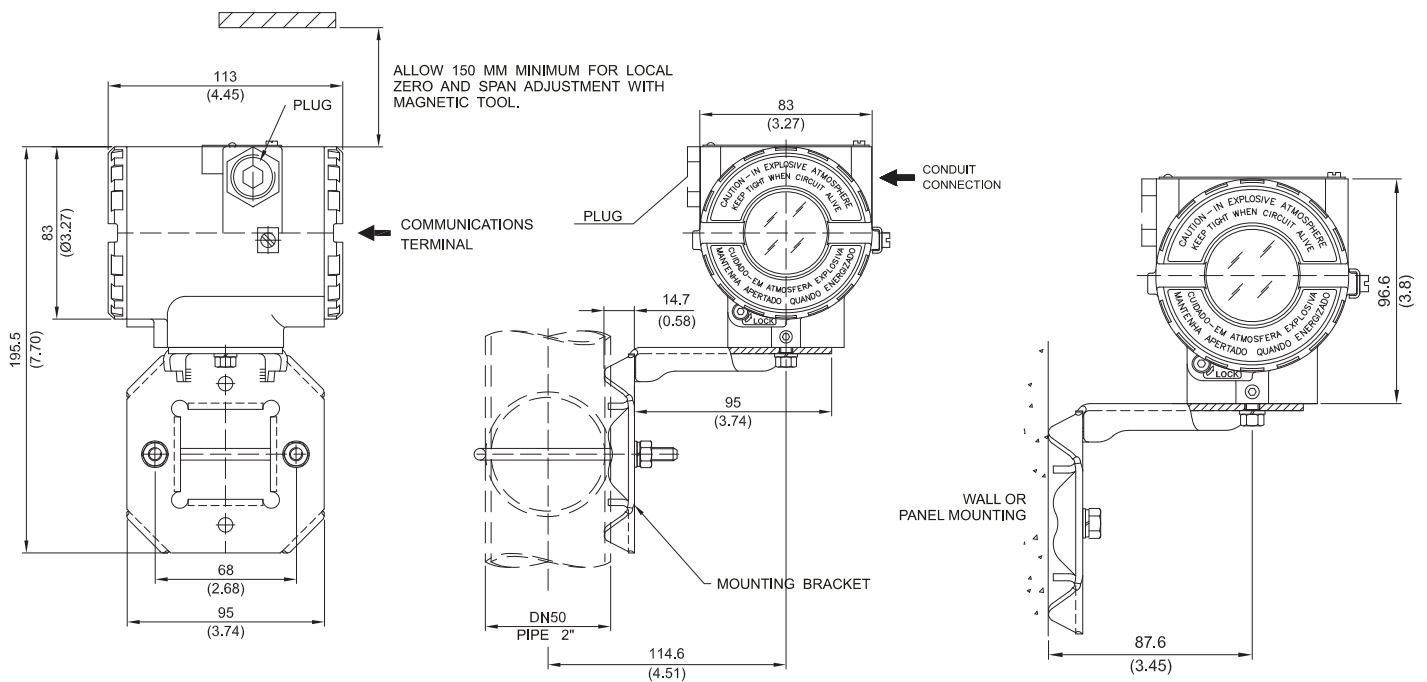

Figure 1.3 - Dimensional Drawing and Mounting Positions



WARNING

HAZARDOUS AREAS

In hazardous areas with explosion proof requirements, the covers must be tightened with at least 8 turns. In order to avoid the penetration moisture or corrosive gases, tighten the O’ring until feeling the O’ring touching the housing. Then, tighten more 1/3 turn (120°) to guarantee the sealing. Lock the covers using the locking screw.

In hazardous zones with intrinsically safe or non-incendive requirements, the circuit entity parameters and applicable installation procedures must be observed.

Cable access to wiring connections is obtained by the two conduit outlets. Conduit threads should be sealed by means of code-approved sealing methods.

Explosion proof, non-incendive and intrinsic safety Factory Mutual certification are standards for **IF302**.

Should other certifications be necessary, refer to the certification or specific standard for installation limitations.

Topology and Network Configuration

Bus topology (See Figure 1.4 - Bus Topology) and tree topology (See Figure 1.5 - Tree Topology Configuration) are supported. Both types have a trunk cable with two terminations. The devices are connected to the trunk via spurs. The spurs may be integrated in the device giving zero spur length. A spur may connect more than one device, depending on the length. Active couplers may be used to extend spur length.

Active repeaters may be used to extend the trunk length.

The total cable length, including spurs, between any two devices in the Fieldbus should not exceed 1900m.

The connection of couplers should be kept less than 15 per 250m.

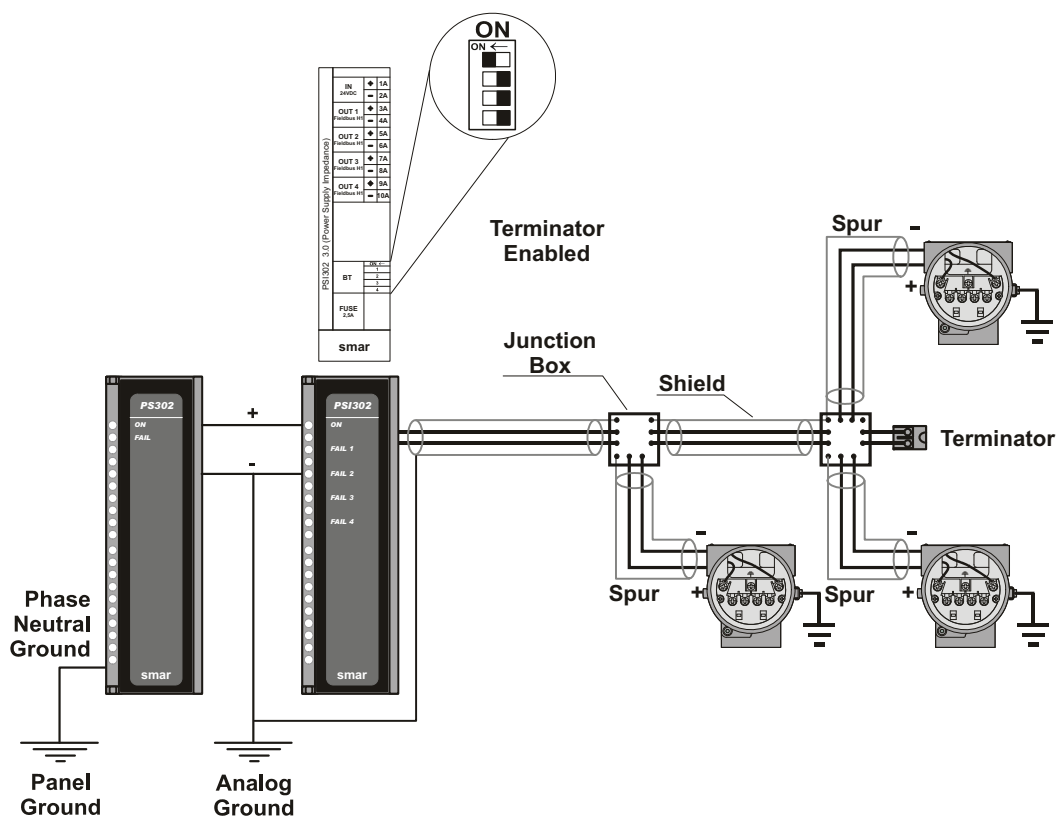

Figure 1.4 - Bus Topology

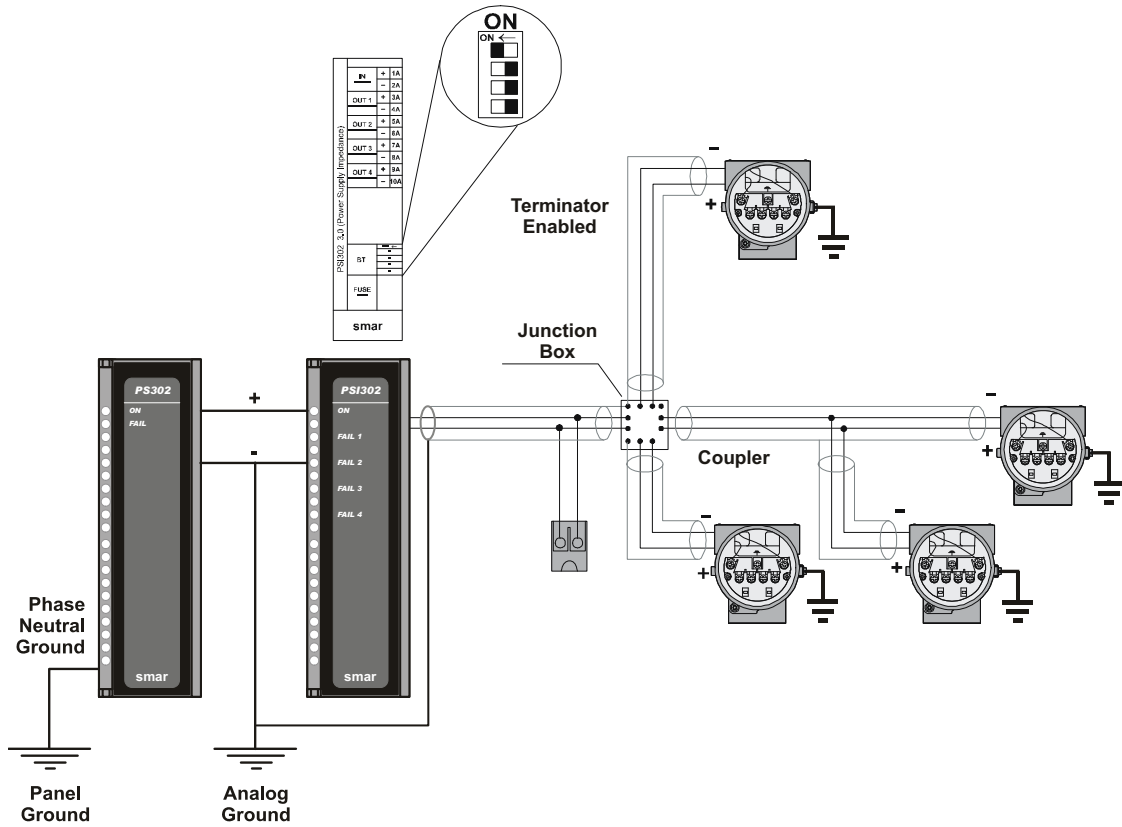

Figure 1.5 - Tree Topology Configuration

Input Wiring

The IF302 accepts up to three current inputs in the range 0-20 mA or 4-20 mA. The three inputs have a common ground and they are protected from reverse polarity signal. The inputs should be connected as per Figure 1.6 - Input Wiring.

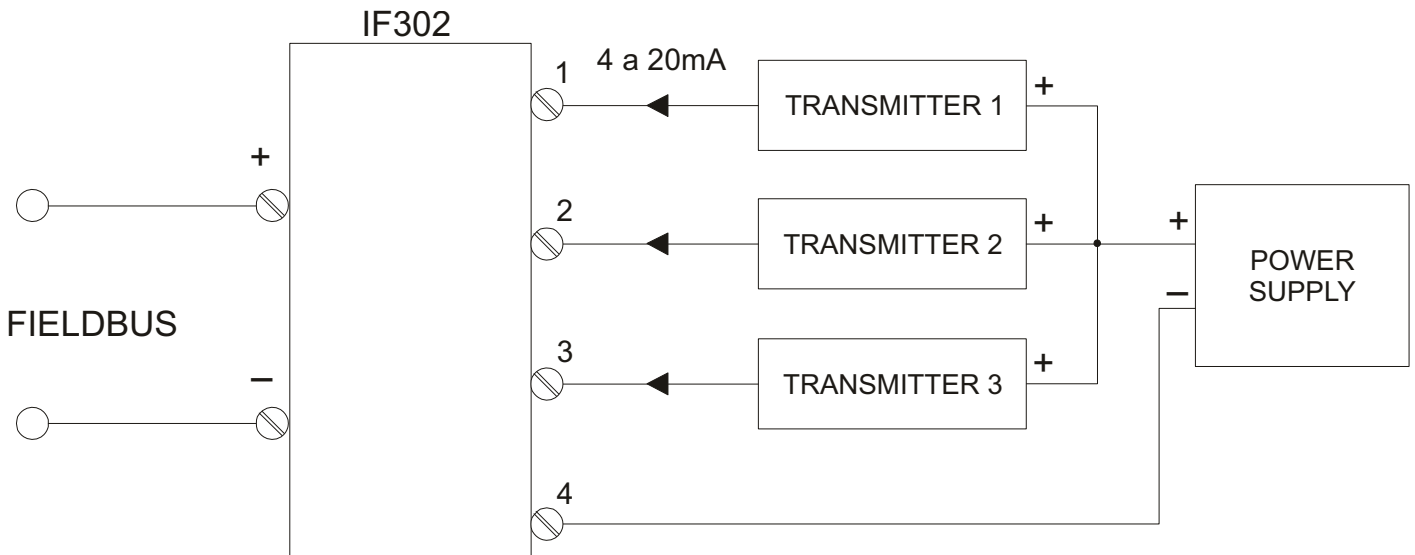

Figure 1.6 - Input Wiring

Note that IF302 can operate with 0-20 mA or 4-20mA transmitters (See Figure 1.7 - Connection).

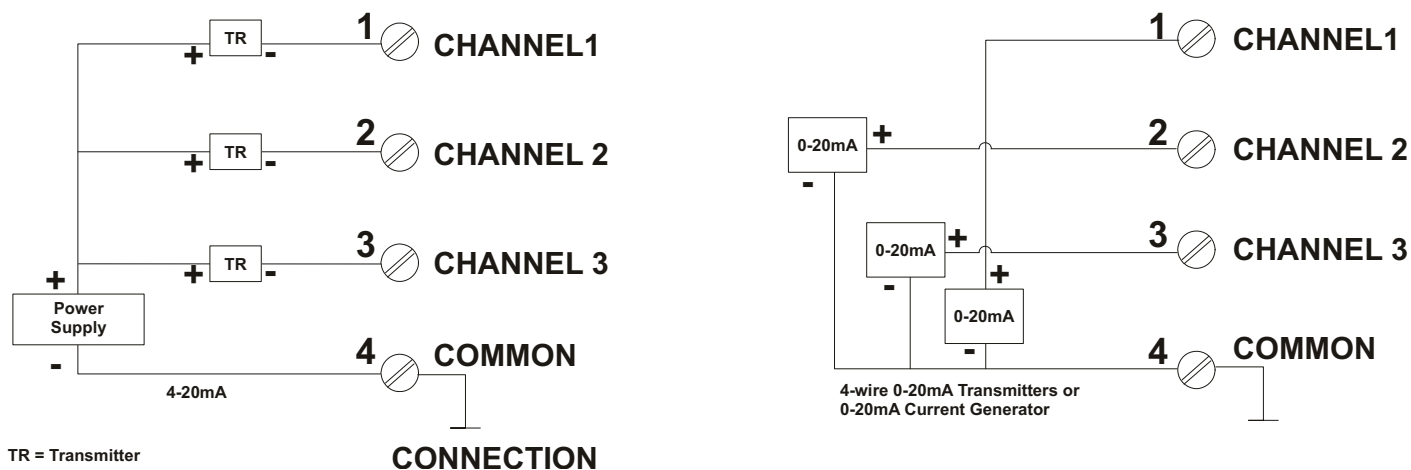

Figure 1.7 - Connection

Avoid routing input wiring close to power cables or switching equipment.



WARNING

Apply in the inputs of the conversor only current levels. **Don't apply tension levels**, because the shunt resistors are of 100R 1W and **tension above 10 Vdc it can damage them.**

Section 2

OPERATION

The **IF302** accepts signals from mA generators such as most conventional transmitters. It is therefore ideal for interfacing existing equipment to a Fieldbus system.

Functional Description – Electronics

Refer to the block diagram (See Figure 2.1 - IF302 Block Diagram). The function of each block is described below.

MUX Multiplexer

The MUX multiplexes the input terminals to ensure that all three channels reach the A/D converter.

A/D Converter

The A/D converts the input signals to a digital format for the CPU.

Signal Isolator

Its function is to isolate the data signal between the input and the CPU.

(CPU) Central Processing Unit, RAM and FLASH

The CPU is the intelligent portion of the converter, being responsible for the management and operation of block execution, self-diagnostics and communication. The program is stored in Flash memory. For temporary storage of data there is a RAM. The data in the RAM is lost if the power is switched off, however the device also has a nonvolatile EEPROM where data that must be retained are stored. Examples of such data are: calibration, configuration and identification data.

Communication Controller

It monitors line activity, modulates and demodulates the signal from network line.

Power Supply

Takes power of the loop-line to power the converter circuitry.

Power Isolation

Just like the signals from the input section, the power to the input section must be isolated.

Display Controller

Receives data from the CPU and drives the Liquid Crystal Display.

Local Adjustment

They are two switches that are magnetically activated. They can be activated by the magnetic tool without mechanical or electrical contact.

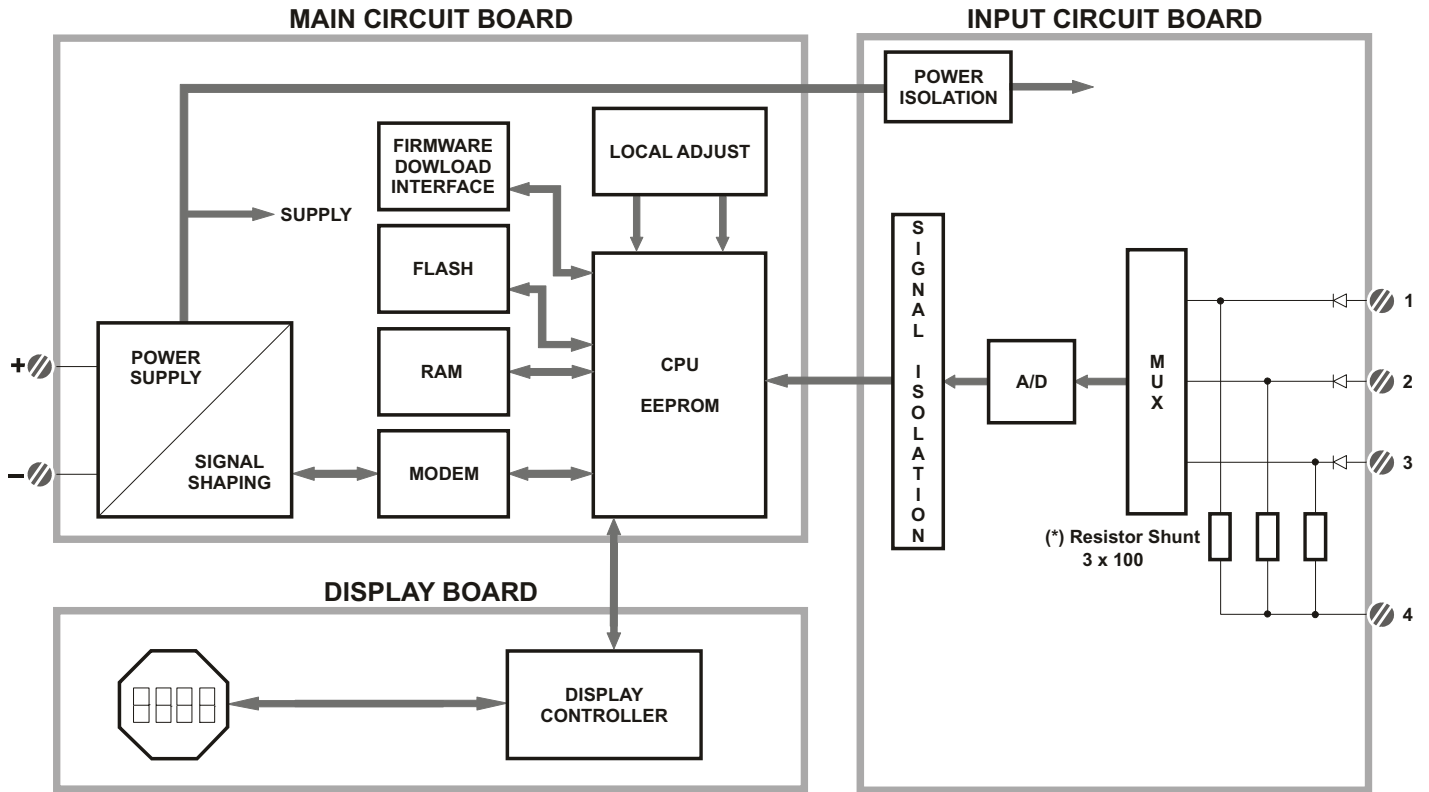

Figure 2.1 - IF302 Block Diagram

*** WARNING**

Apply in the inputs of the conversor only current levels. **Don't apply tension levels**, because the shunt resistors are of 100R 1W and **tension above 10 Vdc** it can damage them.

Section 3

CONFIGURATION

One of the many advantages of Fieldbus is that device configuration is independent of the configurator. The **IF302** may be configured by a third party terminal or operator console.

The **IF302** contains three input transducer blocks, one resource block, one display transducer block and function blocks.

Function Blocks are not covered in this manual. For explanation and details of function blocks, see the "Function Blocks Manual".

Transducer Block

Transducer block insulates function block from the specific I/O hardware, such as sensors and actuators. Transducer block controls access to I/O through manufacturer specific implementation. This permits the transducer block to execute as frequently as necessary to obtain good data from sensors without burdening the function blocks that use the data. It also insulates the function blocks from the manufacturer specific characteristics of certain hardware.

By accessing the hardware, the transducer block can get data from I/O or passing control data to it. The connection between Transducer block and Input/Output Function blocks is called channel. Normally, transducer blocks perform functions, such as linearization, characterization, temperature compensation, control and exchange data to/from hardware.

How to Configure a Transducer Block

The transducer block has an algorithm, a set of contained parameters and a channel connecting it to a function block.

The algorithm describes the behavior of the transducer as a data transfer function between the I/O hardware and other function block. The set of contained parameters, it means, you are not able to link them to other blocks, defines the user interface to the transducer block. They can be divided into Standard and Manufacturer Specific.

The standard parameters will be present for such class of device, as pressure, temperature, actuator, etc., whatever is the manufacturer. Oppositely, the manufacturers specific ones are defined only by its manufacturer. As common manufacturer specific parameters, we have calibration settings, material information, linearization curve, etc.

When you perform a standard routine as a calibration, you are conducted step by step by a method. The method is generally defined as guide line to help the user to make common tasks. The **SYSCON** configurator identifies each method associated to the parameters and enables the interface to it.

Terminal Number

The terminal number, which references a physical input, which is sent internally from the specified transducer output to function block.

It starts at one (1) for transducer number one until three (3) for transducer number three.

The channel number of the AI block is related to the transducer's terminal number. Channel number 1, 2, 3 corresponds bi-univocally to the terminal block with the same number. Therefore, all the user has to do is to select combinations: (1.1), (2.2), (3,3) for (CHANNEL, BLOCK).

Primary Value Status

The status of the Primary Value can follow the NAMUR NE 43 as showed bellow:

3.80 mA < input < 20.5 mA → GOOD

input = 3.80 mA or input = 20.5 → UNCERTAIN

input <= 3.6 mA or input >= 21.0 mA → BAD

To disable this feature, just write a number different from 4 or 20 in the Transducer xd_scale parameter.

Current Trim

The **IF302** provides the capability of making a trim in the input channels, if necessary.

A trim is necessary if the indicator reading of the transducer block output differs from the actual physical output. The reason may be:

- The user's current meter differs from the factory standard.
- The converter had its original characterization shifted by over-load or by long term drift.

The user can check the calibration of the transducer output by measuring the actual current in the input and compare it with the device's indication (of course an appropriate meter shall be used). If a mismatch is detected, a trim can be done.

Trim can be done in two points:

Lower Trim: Is used to trim the output at the lower range.

Upper Trim: Is used to trim the output at the upper range.

These two points define the linear characteristic of the output. Trim in one point is independent from the other.

There are at least two ways of doing the trim: using local adjustment or using **SYSCON** (the System Configurator from **SMAR**).

When doing the trim, make sure you are using an appropriate meter (with the necessary accuracy).



Via SYSCON

The channel number of the AI block is related to the transducer's terminal block number. Channel number 1,2,3 corresponds bi-univocally to the terminal block with the same number. Therefore, all the user has to do is to select combinations: (1,1), (2,2), (3,3), for (CHANNEL, TERMINAL NUMBER).

This parameter selects the terminal number which the input current will be generated and calibrated.

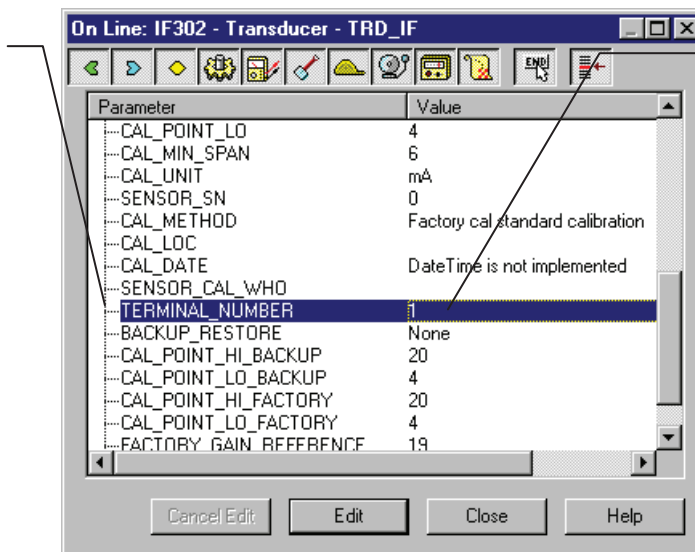

In this case the channel 1 was chosen.

Figure 3.1 - Current Trim - IF302



It is possible to calibrate the current inputs of the transmitter by means of parameters CAL_POINT_LO and CAL_POINT_HI.

Let's take the lower value as an example:

Supply 4 mA or the lower value to the terminal block and wait until the readout of parameter PRIMARY_VALUE stabilizes.

Write 4.00 or the lower value in parameter CAL_POINT_LO. For each value written a calibration is performed at the desired point.

This parameter indicates where the converter should be when the setpoint lower value is 0%.

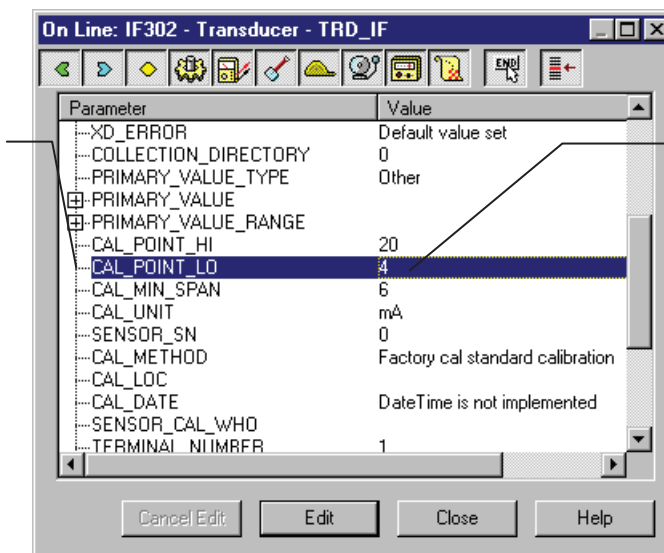

The desired value should be entered.

Figure 3.2 - Current Trim - IF302



Let's take the upper value as an example:

Supply 20 mA or the upper value to the terminal block and wait until the readout of parameter PRIMARY_VALUE stabilizes.

Write 20.00 or the upper value in parameter CAL_POINT_HI. For each value written a calibration is performed at the desired point.

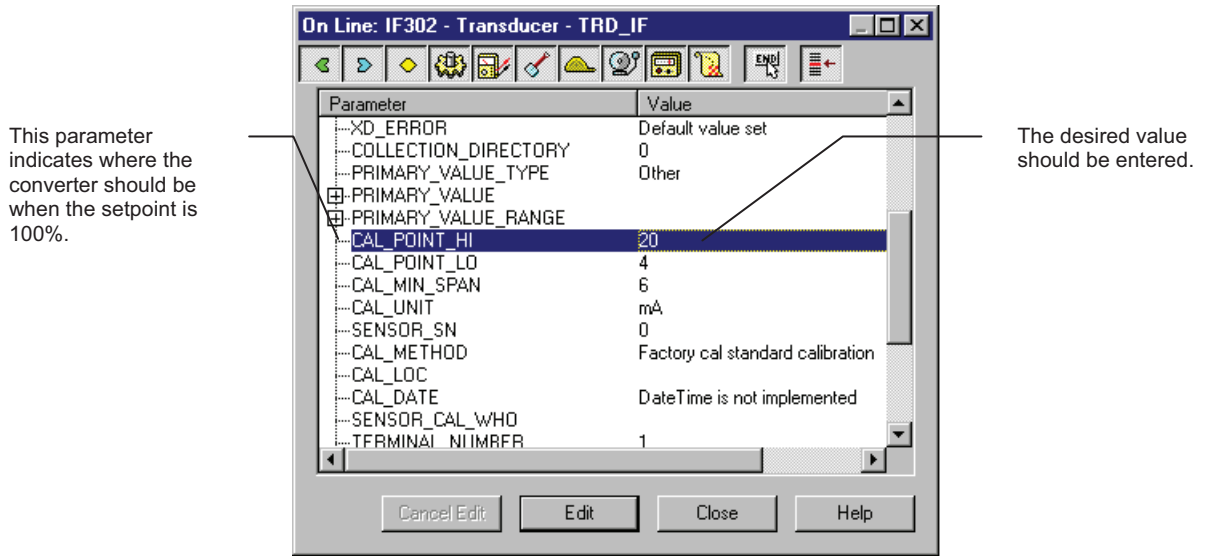

Figure 3.3 - Current Trim - IF302



WARNING

It is recommendable that a convenient engineering unit be chosen by means of parameter XD_SCALE of the Analog Input Block, considering that the range limits of the sensor must be respected, these being 100% and 0%.

It is also recommendable, for every new calibration, to save existing trim data in parameters CAL_POINT_LO_BACKUP and CAL_POINT_HI_BACKUP, by means of parameter BACKUP_RESTORE, using option LAST_TRIM_BACKUP.

Via Local Adjustment

The **IF302** has 3 input transducers and its device leaves SMAR with factory settings. The factory setting establishes only the transducers #1 as default for local adjustment. In order to configure the others via local adjustment, the user should configure them in the display transducer via SYSCON, according specific instructions for this transducer block.

In order to enter the local adjustment mode, place the magnetic tool in orifice "Z" until flag "MD" lights up in the display. Remove the magnetic tool from "Z" and place it in orifice "S" until the message "LOC ADJ" is displayed. The message will be displayed during approximately 5 seconds after the user removes the magnetic tool from "S". By placing the magnetic tool the user will be able to access the local adjustment tree in the monitoring mode.

Browse to parameter P_VAL (PRIMARY_VALUE).

Supply 4.0mA or the lower value to the terminal block and wait until the read of the parameter stabilizes in the display.

Browse to parameter "LOWER". After that, in order to start calibration, the user will act on the parameter "LOWER" by placing the magnetic tool in "S" down to 4.0 mA.

Let's take the upper value:

Supply 20.0mA or the upper value to the terminal block and wait until the readout of parameter P_VAL stabilizes, and then actuate parameter UPPER up to 20.0.

Trim mode exits via local adjustment automatically when the magnetic tool is not used during approximately 16 seconds.



NOTE

Keep in mind that even when parameters LOWER or UPPER present the desired value, they must be actuated so that calibration is performed.

Limit Conditions for Calibration:

For every writing operation in the transducer blocks there is a code indication for the operation associated with the writing method. These codes appear in parameter XD_ERROR every time a calibration is performed. Code 16, for example, indicates a successfully performed operation.

Lower:

$0.0\text{mA} < \text{NEW_LOWER} < 9.0\text{mA}$
Otherwise, XD_ERROR = 22

Upper:

$15.0\text{ mA} < \text{NEW_UPPER} < 22.0\text{mA}$
Otherwise, XD_ERROR = 22.



NOTE

Codes for XD_ERROR:

... 16: Default Value Set
... 22: Out of range
... 26: Invalid Calibration request
... 27: Excessive Correction

Display Transducer Block

The local adjustment tree is completely configured by **SYSCON**. It means, the user can select the best options to fit his application. From factory, it is configured with the options to set the Upper and Lower trim, for monitoring the input transducer output and check the Tag. Normally, the transmitter is much better configured by **SYSCON**, but the local functionality of the LCD permits an easy and fast action on certain parameters, since it does not rely on communication and network wiring connections. Among the possibilities by Local Adjustment, the following options can be emphasized: Mode block, Outputs monitoring, Tag visualization and Tuning Parameters setting.

The interface between the user is described very detailed on the "General Installation, Operation and Maintenance Procedures Manual". Please take a detailed look at this manual in the chapter related to "Programming Using Local Adjustment". It shows significantly the resources on this transducer display. All Series 302 field devices from SMAR have the same methodology to handle with it. So, since the user has learned once, he is capable to handle all kind of field devices from SMAR.

All function blocks and transducers defined according Foundation Fieldbus™ have a description of their features written on binary files, by the Device Description Language. This feature permits that third parties configurator enabled by Device Description Service technology can interpret these features and make them accessible to configure. The Function Blocks and Transducers of Series 302 have been defined rigorously according the Foundation Fieldbus specifications in order to be interoperable to other parties.

In order to enable the local adjustment using the magnetic tool, it is necessary to previously prepare the parameters related with this operation via **SYSCON** (System Configurator). The Figure 3.8 - Parameters for Local Adjustment Configuration and the Figure 3.11 - Step 1 - IF302 show all parameters and their respective values, which shall be configured in accordance with the necessity of being locally adjusted by means of the magnetic tool. All values shown on the display are default values.

There are seven groups of parameters, which may be pre-configured by the user in order to allow a possible configuration by means of the local adjustment. As an example, let's suppose that you don't want to show some parameters; in this case, simply write an invalid Tag in the parameter, Block_Tag_Param_X. Doing this, the device will not take the parameter related (indexed) to the Tag as a valid parameter.

Definition of Parameters and Values

Block_Tag_Param

This is tag of the block to which the parameter belongs. Use up to a maximum of 32 characters.

Index_Relative

This is the index related to the parameter to be actuated or viewed (0, 1, 2...). Refer to the Function Blocks Manual to know the desired indexes, or visualize them on the SYSCON by opening the desired block.

Sub_Index

In case you wish to visualize a certain tag, opt for the index relative equal to zero, and for the sub-index equal to one (refer to paragraph Structure Block in the Function Blocks Manual).

Mnemonic

This is the mnemonic for the parameter identification (it accepts a maximum of 16 characters in the alphanumeric field of the display). Choose the mnemonic, preferably with no more than 5 characters because, this way, it will not be necessary to rotate it on the display.

Inc_Dec

It is the increment and decrement in decimal units when the parameter is Float or Float Status time, or integer, when the parameter is in whole units.

Decimal_Point_Number

This is the number of digits after the decimal point (0 to 3 decimal digits).

Access

The access allows the user to read, in the case of the "Monitoring" option, and to write when "action" option is selected, then the display will show the increment and decrement arrows.

Alpha_Num

These parameters include two options: value and mnemonic. If option value is selected, the display will show data both in the alphanumeric and in the numeric fields; this way, in the case of a data higher than 10000, it will be shown in the alphanumeric field.

If option mnemonic, the display will show the data in the numeric field and the mnemonic in the alphanumeric field.



In case you wish to visualize a certain tag, opt for the index relative equal to zero, and for the sub-index equal to one (refer to paragraph Structure Block in the Function Blocks Manual).

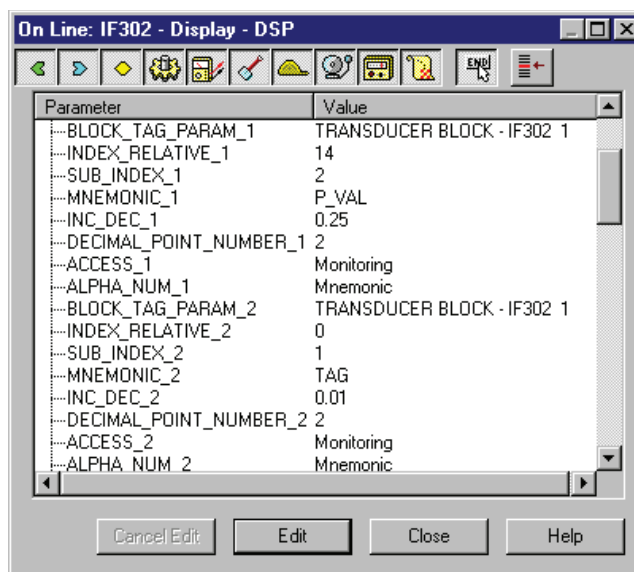

Figure 3.4 - Parameters for Local Adjustment Configuration

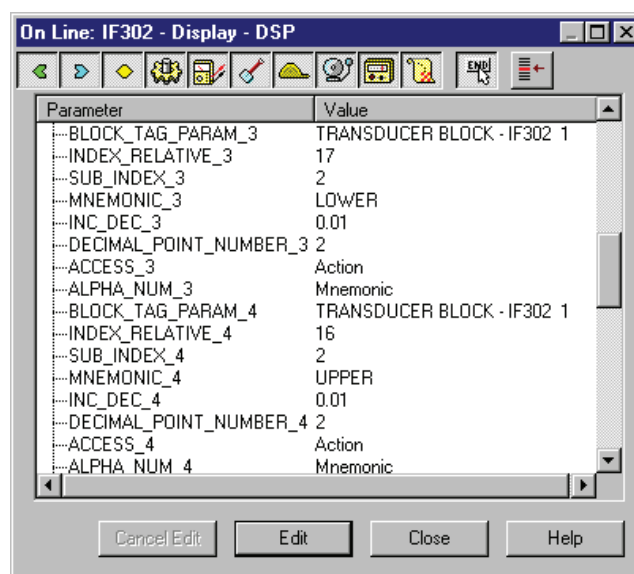

Figure 3.5 - Parameters for Local Adjustment Configuration

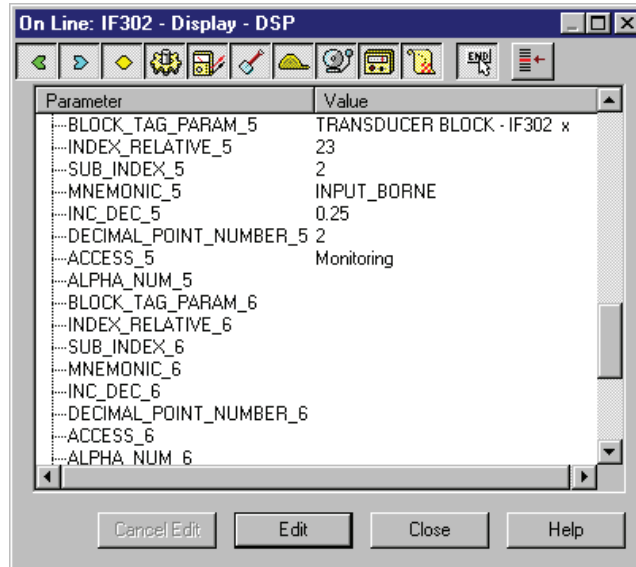

Figure 3.6 - Parameters for Local Adjustment Configuration

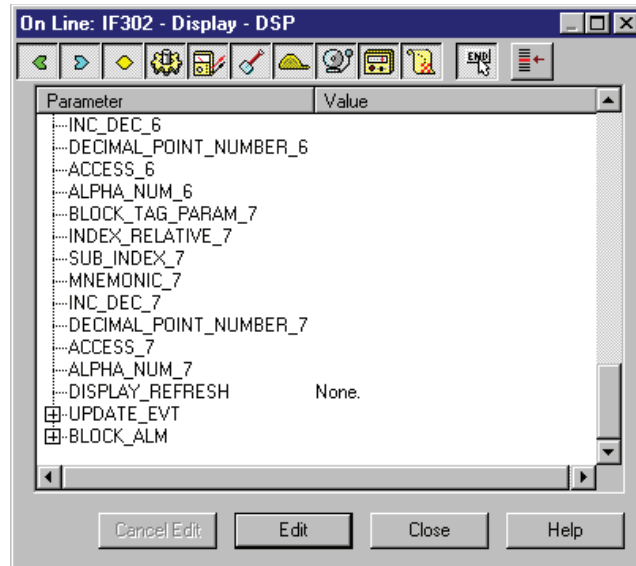
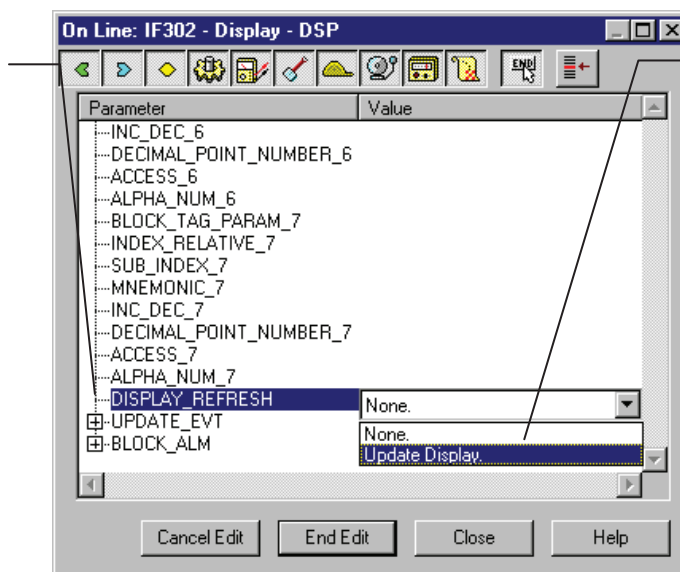

Figure 3.7 - Parameters for Local Adjustment Configuration

This parameter updates the local adjustment programming tree configured on each device.



The option "update" should be selected in order to execute the upgrade of local adjustment programming tree.

After its step all the parameters selected will be show on the LCD display.

Figure 3.8 - Parameters for Local Adjustment Configuration

Programming Using Local Adjustment

The converter has two holes for magnetic switches activated by the magnetic tool located under the identification plate (See Figure 3.9). These magnetic switches are activated by one magnetic tool.

This magnetic tool enables adjustment of the most important parameters of the blocks. It also enables pre-configuration of the communication.

The jumper J1 on top of the main circuit board must be in place for this function to be enabled and the transmitter must be fitted with the digital display for access to the local adjustment. Without the display the local adjustment is not possible.

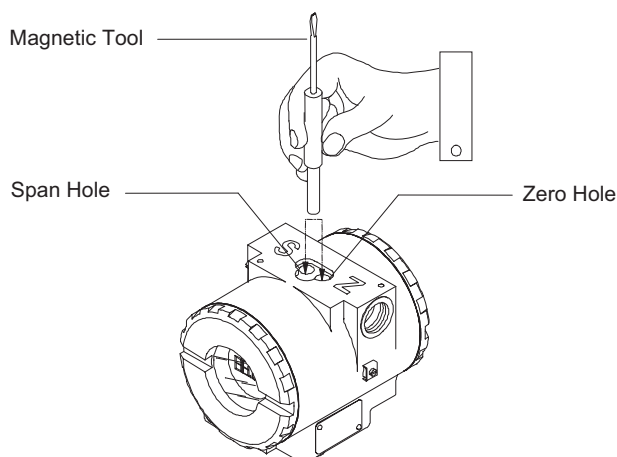

Fig. 3.9 - Local Adjustment Holes

Table 3.1 shows the actions on the Z and S holes on the LD302 when Local Adjustment is enabled.

HOLE	ACTION
Z	Initializes and rotates through the available functions.
S	Selects the function shown in the display.

Table 3.1 - Purpose of the holes on the Housing

J1 Jumper Connections

If J1 (see figure 3.10) is connected to ON, it is possible to simulate values and status through the SIMULATE parameter, from the function blocks.

W1 Jumper Connections

If W1(see figure 3.10) is connected to ON, the local adjustment programming tree is enabled, the block parameters can be adjusted and the communication can be pre-configured via local adjustment.

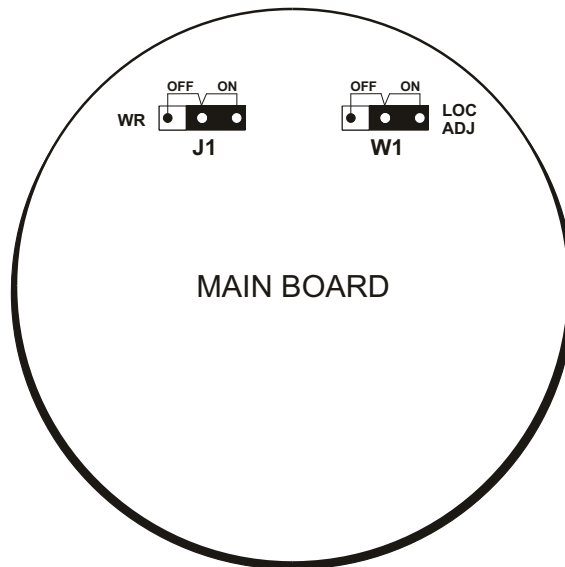
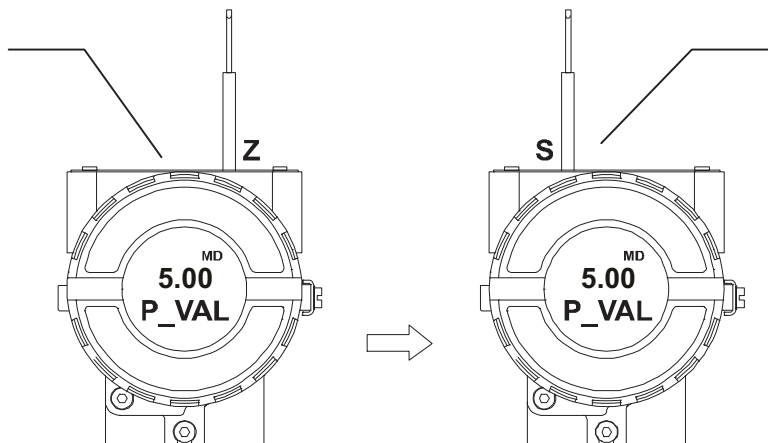

Fig. 3.10 - J1 and W1 Jumpers

In order to start the local adjustment, place the magnetic tool in orifice **Z** and wait until letters **MD** are displayed.



Place the magnetic tool in orifice **S** and wait during 5 seconds.

Figure 3.11 - Step 1 - IF302

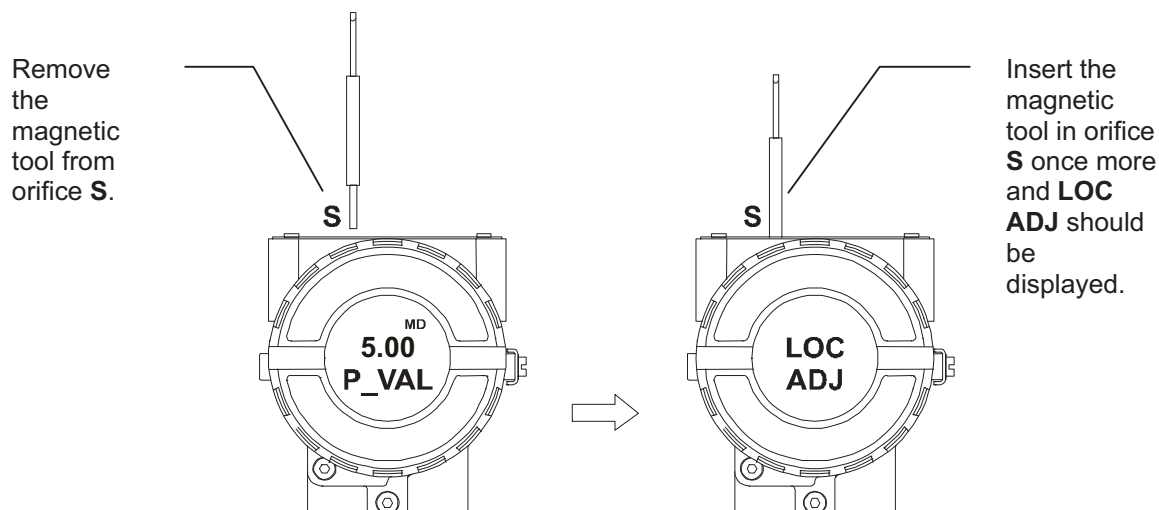

Figure 3.12 - Step 2 - IF302

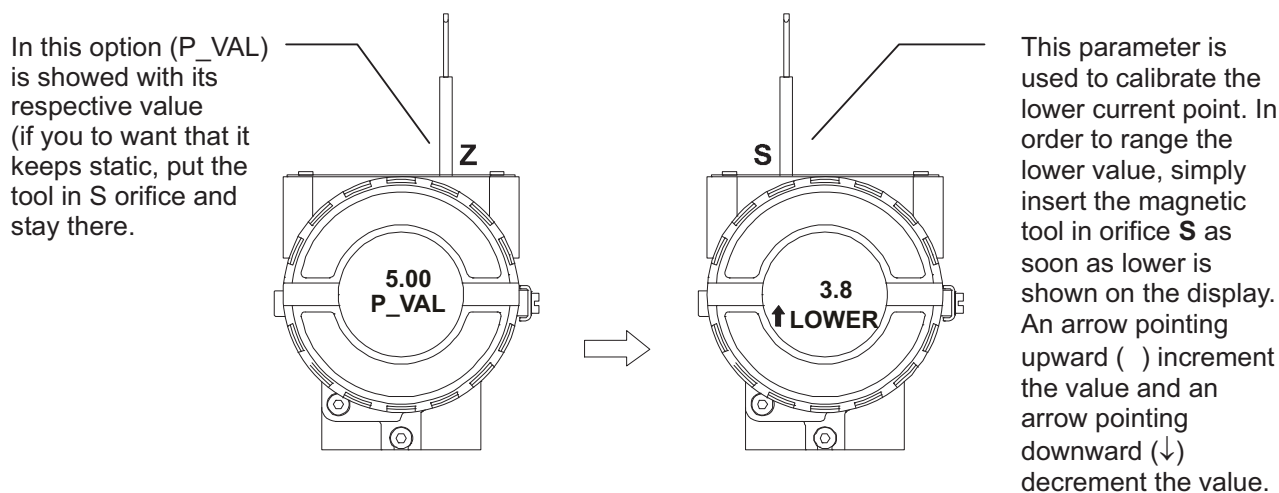

Figure 3.13 - Step 3 - IF302

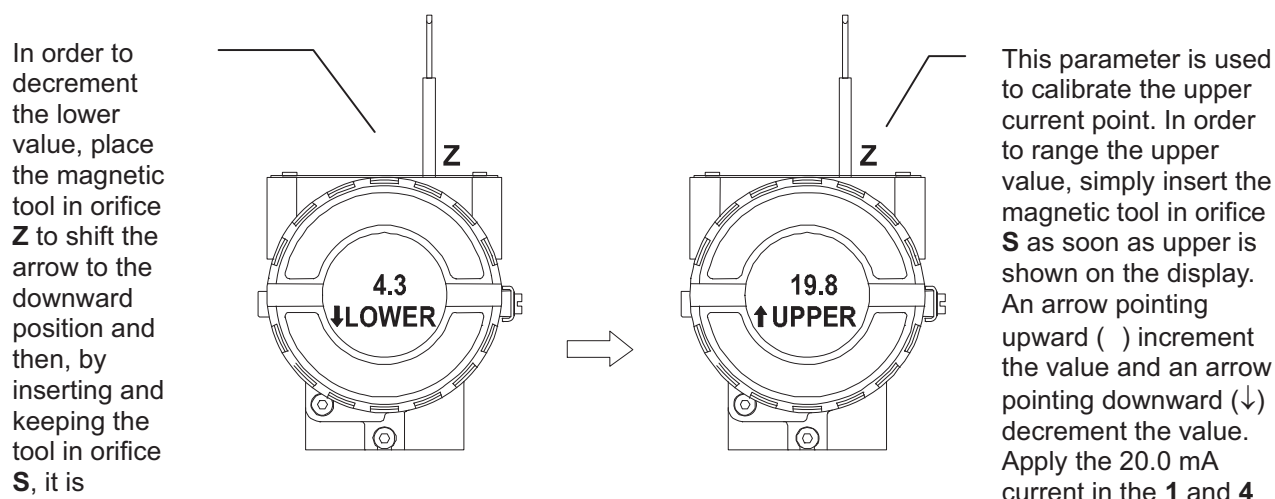

Figure 3.14 - Step 4 - IF302

a) In order to decrement the address value, place the magnetic tool in orifice **Z** to shift the arrow to the downward position and then, by inserting and keeping the tool in orifice **S**, it is possible to

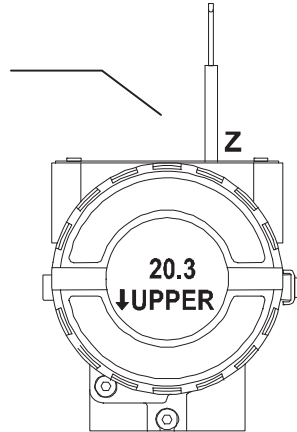

Figure 3.15 - Step 5 - IF303

NOTE

This Local adjustment configuration is a suggestion only. The user may choose his preferred configuration via SYSCON, simply configuring the display block (refer to paragraph Display Transducer Block).

Section 4

MAINTENANCE

General

SMAR **IF302** Current to Fieldbus Converters are extensively tested and inspected before delivery to the end user. Nevertheless, during their design and development, consideration was given to the possibility of repairs by the end user, if necessary.

In general, it is recommended that the end user do not try to repair printed circuit boards. Instead, he should have spare circuit boards, which may be ordered from SMAR whenever necessary.

Troubleshooting

Symptom: No Quiescent Current

Probable Sources of Trouble:

Converter Fieldbus Connections

Check wiring polarity and continuity.

Power Supply

Check power supply output. The voltage at the **IF302** Fieldbus terminals must be between 9 and 32 VDC.

Electronic Circuit Failure

Check the boards for defect by replacing them with spare ones.

Symptom: No Communication

Probable Source of Trouble

Network Connections

Check the network connections: devices, power supply, and terminators.

Network Impedance

Check the network impedance (power supply impedance and terminators).

Transmitter Configuration

Check configuration of communication parameters of converter.

Network Configuration

Check communication configuration of the network.

Electronic Circuit Failure

Try to replace the converter circuit with spare parts.

Symptom: Incorrect Inputs

Probable Source of Trouble:

Input Terminals Connection

Check wiring polarity and continuity.

Conventional Transmitter

Verify if the conventional transmitter is working properly or if it has the necessary voltage. Remember that **IF302** has a 100 ohms plus 0.8 V input impedance.

Calibration

Check calibration of **IF302** and the conventional transmitters.

If the problem is not presented in the table above follow the Note below:

NOTE
<p>The Factory Init should be tried as a last option to recover the equipment control when the equipment presents some problem related to the function blocks or the communication. This operation must only be carried out by authorized technical personnel and with the process offline, since the equipment will be configured with standard and factory data.</p> <p>This procedure resets all the configurations run on the equipment, after which a partial download should be performed.</p> <p>Two magnetic tools should be used to this effect,. On the equipment, withdraw the nut that fixes the identification tag on the top of the housing, so that access is gained to the "S" and "Z" holes.</p> <p>The operations to follow are:</p> <ol style="list-style-type: none">1) Switch off the equipment, insert the magnetic tools and keep them in the holes (the magnetic end in the holes);2) Feed the equipment;3) As soon as Factory Init is shown on the display, take off the tools and wait for the "5" symbol on the right upper corner of the display to unlit, thus indicating the end of the operation. <p>This procedure makes effective all the factory configuration and will eliminate eventual problems with the function blocks or with the equipment communication.</p>

Disassembly Procedure

Refer to Figure 4.1 - IF302 Exploded View Make sure to disconnect power supply before disassembling the converter.

To remove the circuit boards (5 and 7) and display (4), first loose the cover locking (8) on the side not marked "Field Terminals", then unscrew the cover (1).



WARNING
<p>The boards have CMOS components, which may be damaged by electrostatic discharges. Observe correct procedures for handling CMOS components. It is also recommended to store the circuit boards in electrostatic-proof cases.</p>

Loose the two screws (3) that anchors the display and the main circuit board. Gently pull out the display, and then the main board (5). To remove the input board (7), first unscrew the two screws (6) that anchors it to the housing (9), and gently pull out the board.

Reassemble Procedure

- Put input board (7) into housing (9).
- Anchors input board with their screws (6).
- Put main board (5) into the housing, ensuring all inter connecting pins are connected.
- Put display (4) into the housing, observing the four mounting positions. "_" should point in the direction desired as UP.
- Anchors main board and display with their screws (3).
- Fit the cover (1) and lock it using the locking screw (8).

Boards Interchangeability

Main and input boards are supposed to stay together, because calibration data from input board circuit is stored in EEPROM of the main board.

**WARNING**

If, for some reason, you separate the input and the main boards, you must do a trim to guarantee precision of the inputs. With mismatched boards, the factory trim will not be so good as it was.

Exploded View

Figure 4.1 - IF302 Exploded View

Accessories

ACCESSORIES	
ORDERING CODE	DESCRIPTION
SD1	Magnetic Tool for Local Adjustment
BC302	Fieldbus/RS232 Interface
SYSCON	System Configurator
PS302	Power Supply
PSI302	Power Supply Impedance
BT302	Terminator
PCI	Process Control Interface

Spare Parts List

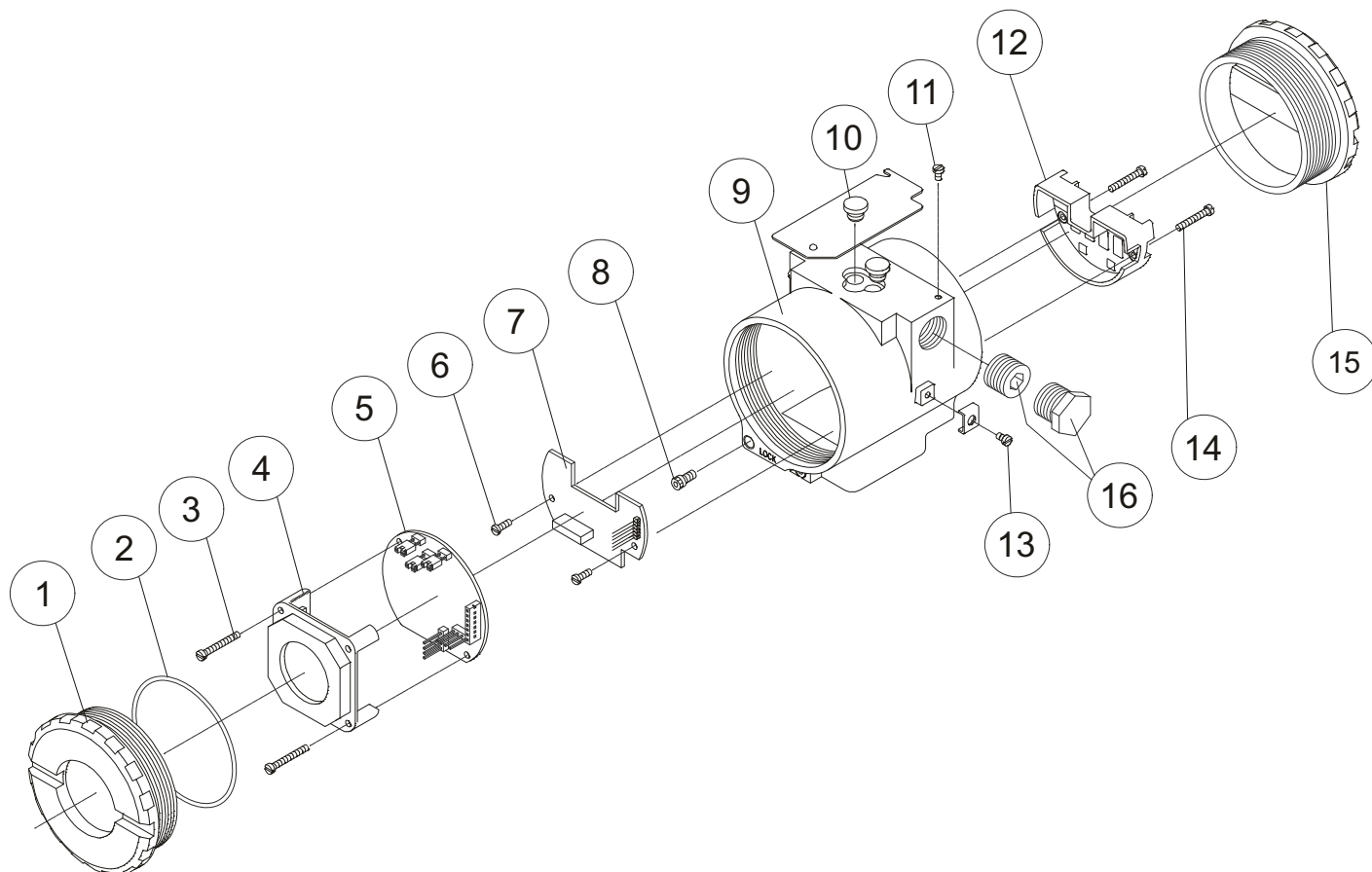
SPARE PARTS LIST				
DESCRIPTION OF PARTS		POSITION	CODE	CATEGORY (NOTE 4)
Cover Without Window (Includes O-Ring)	Aluminium	1 and 15	204-0102	
	316 Stainless Steel	1 and 15	204-0105	
Cover With Window for Indication (Includes O-Ring)	Aluminium	1	204-0103	
	316 Stainless Steel	1	204-0106	
O-Rings (Note 2)	Cover, Buna-N	2	204-0122	B
Aluminium Housing Main Board Screw	Units With Indicator	3	304-0118	
	Units Without Indicator	3	304-0117	
316 Stainless Steel Housing Main Board Screw	Units With Indicator	3	204-0118	
	Units Without Indicator	3	204-0117	
Digital Indicator		4	214-0108	
Main and Input Circuit Board Assembly		5 and 7	334-0150	A
Input Board Screw	Aluminium Housing	6	314-0125	
	316 Stainless Steel Housing	6	214-0125	
Cover Locking Screw		8	204-0120	
Housing, Aluminium (Note 1)	½ - 14 NPT	9	324-0150	
	M20 x 1.5	9	324-0151	
	PG 13.5 DIN	9	324-0152	
Housing, 316 Stainless Steel (Note 1)	½ - 14 NPT	9	324-0153	
	M20 x 1.5	9	324-0154	
	PG 13.5 DIN	9	324-0155	
Local Adjustment Protection Cap		10	204-0114	
Identification Plate Fixing Screw		11	204-0116	
Terminal Insulator		12	314-0123	
External Ground Screw		13	204-0124	
Terminal Holding Screw	Housing in Aluminium	14	304-0119	
	Housing in 316 Stainless Steel	14	204-0119	
Six-Sided Plug 1/2" NPT Internal BR Ex	Bichromated Carbon Steel	16	400-0808	
	Bichromated 304 Stainless Steel	16	400-0809	
Six-Sided Plug 1/2" NPT Internal	Bichromated Carbon Steel	16	400-0583-11	
	Bichromated 304 Stainless Steel	16	400-0583-12	
Six-Sided Plug M20 X 1.5 External BR Ex d	316 Stainless Steel	16	400-0810	
Six-Sided Plug PG13.5 External BR Ex d	316 Stainless Steel	16	400-0811	
Mounting Bracket for 2" Pipe Mounting (Note 3)	Carbon Steel	-	214-0801	
	316 Stainless Steel	-	214-0802	
	Carbon Steel Bolts, Nuts, Washers and U-clamp in Stainless Steel	-	214-0803	

- Note:**
- 1 - It includes terminal holder insulator, bolts (cover lock, grounding and terminal holder insulator) and identification plate without certification.
 - 2 - O-Rings are packaged in packs of 12 units.
 - 3 - Including U-clamp, nuts, bolts and washers. Spare Parts List
 - 4 - For category **A**, it is recommended to keep, in stock, 25 parts installed for each set, and for category **B**, 50.

Section 5

TECHNICAL CHARACTERISTICS

Functional Specifications

Input Signal (Field Values)

0-20 mA, 4-20 mA or any within 0 and 20 mA. Reverse polarity protected (*).

Output Signal (Communication)

Digital only, Foundation™ Fieldbus, 31.25 kbits/s voltage mode with bus power.

Input Impedance

Resistive 100 Ohms , plus a 0.8 V drop over diode in forward direction.

Power Supply

Bus power 9 - 32 Vdc.

Current consumption quiescent 12 mA.

Output impedance

Non-intrinsic safety from 7.8 KHz - 39 KHz should be greater or equal to 3 K Ω .

Intrinsic safety output impedance (assuming an IS barrier in the power supply) from 7.8 KHz - 39 KHz should be greater or equal to 400 Ω .

Indication

Optional 4 1/2-digit numerical and 5-character alphanumeric LCD indicator.

Hazardous Location Certification

Explosion proof, weather proof and intrinsically safe CENELEC and FM standards.

Temperature Limits

Operation: -40 to 85°C (-40 to 185°F)

Storage: -40 to 120°C (-40 to 250°F)

Display: -10 to 75°C (14 to 167°F) operation

-40 to 85°C (-40 to 185°F) without damage.

Humidity Limits

0 to 100% RH.

Turn-on Time

Approximately 10 seconds.

Update Time

Approximately 0.3 second.

*** WARNING**

Apply in the inputs of the conversor only current levels. **Don't apply tension levels**, because the shunt resistors are of 100R 1W and **tension above 10 Vdc it can damage them**.

Performance Specifications

Accuracy

0.03% of span for 4 - 20 mA, 5 μ A for others spans.

Ambient Temperature Effect

For a 10°C variation: \pm 0.05%.

Vibration Effect

Meets SAMA PMC 31.1.

Electro-Magnetic Interference Effect

Designed to comply with IEC 801.

Physical Specifications

Electrical Connection

1/2 - 14 NPT, Pg 13.5 or M20 x 1.5.

Material of Construction

Injected low copper aluminium with polyester painting or 316 Stainless Steel housing, with Buna N O-rings on cover (NEMA 4X, IP67).

Mounting

With an optional bracket can be installed on a 2" pipe or fixed on a wall or panel.

Weight

Without display and mounting bracket: 0.80 kg.

Add for digital display: 0.13 kg.

Add for mounting bracket: 0.60 kg.

Ordering Code

MODEL	CURRENT TO FIELDBUS CONVERTER			
IF302	CODE	Local Indicator		
	0	Without Digital Indicator		
	1	With Digital Indicator		
	CODE	Mounting Bracket for 2" Pipe Mounting		
	0	Without Bracket		
	1	Carbon Steel Bracket		
	2	316 SST Bracket		
	CODE	Electrical Connections		
	0	1/2-14 NPT		
	A	M20 x 1.5		
	B	Pg 13.5 DIN		
	CODE	Options *		
	H1	316 SST Housing		
	A1	316 SST Bolts		
	ZZ	Special Options - Specify		
IF302	1	1	0	*

- Leave it blank for no optional items.

Returning Materials

Should it become necessary to return the converter to SMAR, simply contact your local agent or SMAR office, informing the defective instrument's serial number, and return it to our factory.

In order to expedite analysis and solution of the problem, the defective item should be returned with a description of the failure observed, with as many details as possible. Other information concerning to the instrument operation, such as service and process conditions, is also helpful.

NON HAZARDOUS OR DIVISION 2 AREA

SAFE AREA APPARATUS
UNSPECIFIED, EXCEPT THAT IT MUST NOT BE SUPPLIED FROM, NOR CONTAIN UNDER NORMAL OR ABNORMAL CONDITIONS, A SOURCE OF POTENTIAL IN RELATION TO EARTH IN EXCESS OF 250VAC OR 250VDC.

ASSOCIATED APPARATUS

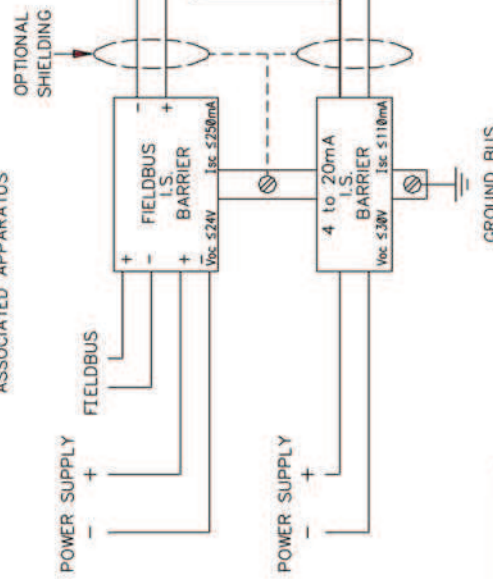

ENTITY PARAMETERS FOR ASSOCIATED APPARATUS
CLASS I,II,III DIV.1, GROUPS A,B,C,D,E,F & G
Ca ≥ CABLE CAPACITANCE +5nF
La ≥ CABLE INDUCTANCE +12uH
FIELDBUS
Voc ≤ 24V
Isc ≤ 250mA
Voc ≤ 30V
Isc ≤ 110mA

HAZARDOUS AREA

- REQUIREMENTS:
- 1 - INSTALLATION MUST BE IN ACCORDANCE WITH THE NATIONAL ELECTRICAL CODE (ANSI/NFPA 70) AND ANSI/ISA-RP12.6
 - 2 - TRANSMITTER SPECIFICATION MUST BE IN ACCORDANCE TO APPROVAL LISTING.
 - 3 - ASSOCIATED APPARATUS GROUND BUS TO BE INSULATED FROM PANELS AND MOUNTING ENCLOSURES.
 - 4 - ASSOCIATED APPARATUS GROUND BUS RESISTANCE TO EARTH MUST BE SMALLER THAN 1(ONE) OHM.
 - 5 - OBSERVE TRANSMITTER POWER SUPPLY LOAD CURVE.
 - 6 - WIRES: TWISTED PAIR, 22AWG OR LARGER.
 - 7 - SHIELD IS OPTIONAL IF USED, BE SURE TO INSULATE THE END NOT GROUNDED.
 - 8 - CABLE CAPACITANCE AND INDUCTANCE PLUS Ci AND Li MUST BE SMALLER THAN Ca AND La OF THE ASSOCIATED APPARATUS.

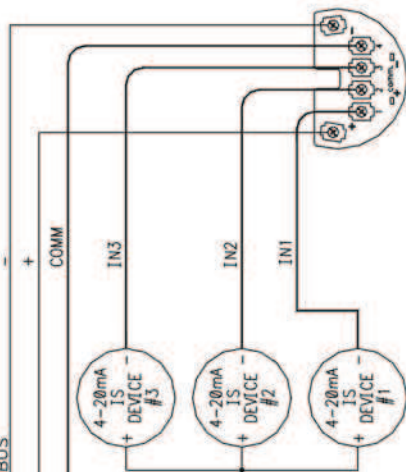

MODEL IF302 - SERIES
CLASS I,II,III DIV.1, GROUPS A,B,C,D,E,F & G
ENTITY VALUES:
FIELDBUS
4-20mA
Ci=5nF Li=12uH
Vmax ≤ 24V
Imax ≤ 250mA

REV.	DESIGN	APPROVED	AREA
3	MELONI 18/08/97	EUGENIO 18/08/97	ALT DE 0095/97
2	MOACIR 05/03/97	EUGENIO 05/03/97	ALT DE 0030/97
1	AROSTI 30/12/96	EUGENIO 30/12/96	ALT DE 0077/96

APPROVAL CONTROLLED BY C.A.R.			
DRAWING	DESIGN	VERIFIED	APPROVED
MELONI 28/03/95	M.MISSAWA 28/03/95	SINASTRE 28/03/95	PELUSO 28/03/95
CUSTOMER:			
EQUIPMENT: IF302			
CONTROL DRAWING			

APPROVED

smar

O.S.

DRAWING N.	REV
102A0081	03
SH. 01/01	

Appendix A

	SRF – Service Request Form		
	Converter from 4-20mA to Fieldbus		
GENERAL DATA			
Model:	IF302 ()	IF303 ()	
Serial Number:	_____		
TAG:	_____		
How many channels are used in IF?	1 ()	2 ()	3 ()
Configuration:	Magnetic Tool ()	PC ()	Software: _____ Version: _____
INSTALLATION DATA			
Type/Model/Manufacturer of device connected to the channel 1: _____			
Type/Model/Manufacturer of device connected to the channel 2: _____			
Type/Model/Manufacturer of device connected to the channel 3: _____			
PROCESS DATA			
Hazardous Area Classification:	() Yes, please specify: _____		
	() No		
	More details: _____		
Types of Interference presents in the area:	Without interference ()	Temperature ()	Vibration () Others: _____
Ambient Temperature:	From _____ °C up to _____ °C		
OCCURRENCE DESCRIPTION			

SERVICE SUGGESTION			
Adjustment ()	Cleaning ()	Preventive Maintenance ()	Update / Up-grade ()
Other: _____			
USER INFORMATION			
Company: _____			
Contact: _____			
Title: _____			
Section: _____			
Phone: _____		Extension: _____	
E-mail: _____		Date: ____ / ____ / ____	
<p>For warranty or non-warranty repair, please contact your representative. Further information about address and contacts can be found on www.smar.com/contactus.asp.</p>			

SMAR WARRANTY CERTIFICATE

1. SMAR guarantees its products for a period of 24 (twenty four) months, starting on the day of issuance of the invoice. The guarantee is valid regardless of the day that the product was installed.
2. SMAR products are guaranteed against any defect originating from manufacturing, mounting, whether of a material or manpower nature, provided that the technical analysis reveals the existence of a quality failure liable to be classified under the meaning of the word, duly verified by the technical team within the warranty terms.
3. Exceptions are proven cases of inappropriate use, wrong handling or lack of basic maintenance compliant to the equipment manual provisions. SMAR does not guarantee any defect or damage caused by an uncontrolled situation, including but not limited to negligence, user imprudence or negligence, natural forces, wars or civil unrest, accidents, inadequate transportation or packaging due to the user's responsibility, defects caused by fire, theft or stray shipment, improper electric voltage or power source connection, electric surges, violations, modifications not described on the instructions manual, and/or if the serial number was altered or removed, substitution of parts, adjustments or repairs carried out by non-authorized personnel; inappropriate product use and/or application that cause corrosion, risks or deformation on the product, damages on parts or components, inadequate cleaning with incompatible chemical products, solvent and abrasive products incompatible with construction materials, chemical or electrolytic influences, parts and components susceptible to decay from regular use, use of equipment beyond operational limits (temperature, humidity, etc.) according to the instructions manual. In addition, this Warranty Certificate excludes expenses with transportation, freight, insurance, all of which are the customer's responsibility.
4. For warranty or non-warranty repair, please contact your representative.

Further information about address and contacts can be found on www.smar.com/contactus.asp
5. In cases needing technical assistance at the customer's facilities during the warranty period, the hours effectively worked will not be billed, although SMAR shall be reimbursed from the service technician's transportation, meals and lodging expenses, as well dismounting/mounting costs, if any.
6. The repair and/or substitution of defective parts do not extend, under any circumstance, the original warranty term, unless this extension is granted and communicated in writing by SMAR.
7. No Collaborator, Representative or any third party has the right, on SMAR's behalf, to grant warranty or assume some responsibility for SMAR products. If any warranty would be granted or assumed without SMAR's written consent, it will be declared void beforehand.
8. Cases of Extended Warranty acquisition must be negotiated with and documented by SMAR.
9. If necessary to return the equipment or product for repair or analysis, contact us.
See item 4.
10. In cases of repair or analysis, the customer must fill out the Revision Requisition Form (FSR) included in the instructions manual, which contains details on the failure observed on the field, the circumstances it occurred, in addition to information on the installation site and process conditions. Equipments and products excluded from the warranty clauses must be approved by the client prior to the service execution.
11. In cases of repairs, the client shall be responsible for the proper product packaging and SMAR will not cover any damage occurred in shipment.

12. In cases of repairs under warranty, recall or outside warranty, the client is responsible for the correct packaging and packing and SMAR shall not cover any damage caused during transportation. Service expenses or any costs related to installing and uninstalling the product are the client's sole responsibility and SMAR does not assume any accountability before the buyer.
13. It is the customer's responsibility to clean and decontaminate products and accessories prior to shipping them for repair, and SMAR and its dealer reserve themselves the right to refuse the service in cases not compliant to those conditions. It is the customer's responsibility to tell SMAR and its dealer when the product was utilized in applications that contaminate the equipment with harmful products during its handling and repair. Any other damages, consequences, indemnity claims, expenses and other costs caused by the lack of decontamination will be attributed to the client. Kindly, fill out the Declaration of Decontamination prior to shipping products to SMAR or its dealers, which can be accessed at www.smar.com/doc/declarationofcontamination.pdf and include in the packaging.
14. This warranty certificate is valid only when accompanying the purchase invoice.